

XPR[®] plasma

Unmatched performance. Unbeatable operating cost.





Contents

- 4 XPR® overview
- 6 Industry leading X-Definition® cut quality
- 10 Optimized productivity and reduced operating costs
- 12 Engineered system optimization
- 14 Ease of use
- 17 Reliability
- 19 Shaping Possibility®

XPR overview

Unmatched performance. Unbeatable operating cost.

The XPR® plasma represents the most significant advance in mechanized plasma cutting technology, ever. These next generation systems redefine what plasma can do by expanding its capabilities and opportunities in ways never before possible. With unmatched X-Definition® cut quality on mild steel, stainless steel and aluminum, XPR increases cut speed, dramatically improves productivity and slashes operating costs. New ease-of-use features and engineered system optimization make XPR easier to run with minimal operator intervention, while also ensuring optimal performance and unmatched reliability.

Industry leading cut quality—X-Definition

The XPR advances HyDefinition® cut quality by blending new technology with refined processes for next generation, X-Definition cutting on mild steel, stainless steel and aluminum.

- Consistent ISO range 2 results on thin mild steel
- Extended ISO range 3 cut quality results compared with earlier plasma technology
- Superior stainless steel cut quality across all thickness ranges
- Superior results on aluminum using Vented Water Injection™ (VWI)

Optimized productivity and reduced operating costs

- Dramatic improvement in consumable life on mild steel applications
- Thicker piercing capability than competitive plasma systems
- Significantly lower operating costs than previous generation technology
- High quality argon marking using the same cutting consumables

Engineered system optimization

- Ramp down error protection significantly increases realized consumable life
- Reduces the impact of catastrophic electrode blowouts which can damage the torch at high current levels



Consistent cuts on mild steel, stainless steel and aluminum.

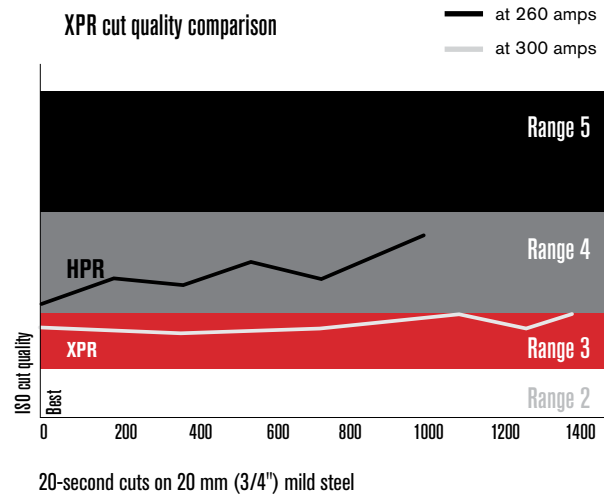

Ease of use

- Intuitive operation and automatic monitoring redefine ease of use
- Full control of all functions and settings via the CNC
- Automatic system monitoring and specific troubleshooting codes for improved maintenance and service prompts

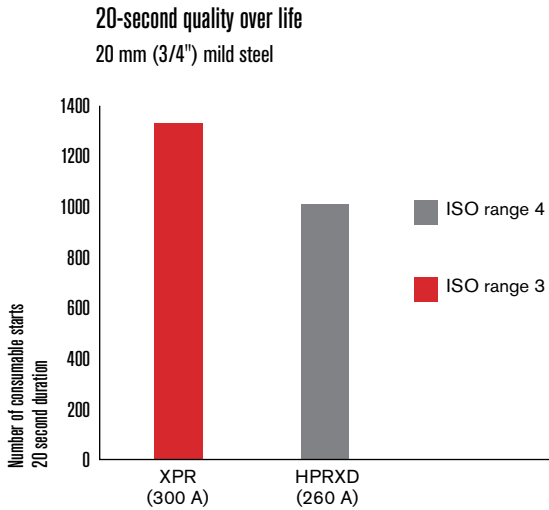

- EasyConnect™ torch lead and one hand torch-to-receptacle connection for fast and easy change-outs
- QuickLock™ electrode for easy consumable replacement
- WiFi in power supply can connect to mobile devices and LAN for multiple system monitoring and service



Industry leading X-Definition cut quality

Torch and consumable technology

X-Definition® improves cut quality and consistency on mild steel, expands the application of Hypertherm Associates' pioneering HyDefinition® process to a broad range of non-ferrous applications and greatly enhances it with a number of critical new cutting technologies.

Expanded HyDefinition technology

Our pioneering HyDefinition technology, featuring a unique two-piece vented nozzle design, aligns and focuses the plasma arc, increasing arc stability and energy density for more consistent, precise cut quality. Previously used primarily on mild steel applications, this foundational technology is now applied to the full range of non-ferrous cutting processes for cleaner, sharper, more consistent edge quality on stainless steel and aluminum.

Vented Water Injection (VWI)

This patent pending process features a vented N₂ plasma and an H₂O shield. Edges are square, angularity is reduced and surface finish is excellent on non ferrous materials, especially aluminum.



Cool nozzle

Patent pending feature on the 220 and 300-amp oxygen process provides liquid cooling directly to the nozzle bore. This cooling is a significant factor in increasing cut quality over the life of the consumables by over 40%.

Cool nozzle

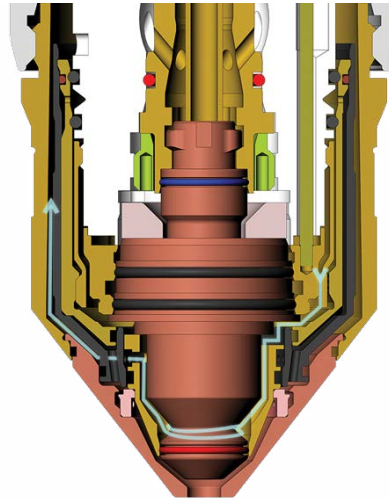

Vent-to-shield technology

This new technology mixes hydrogen reclaimed from the vented plasma gas with the shield gas to reduce angularity and deliver more consistent edge color on stainless steel up to 12 mm (1/2").

Plasma dampening

Patent pending plasma dampening delivers increased arc density and cut speeds on thin stainless while maintaining arc stability and smoother cut edges.

PowerPierce

Patented PowerPierce® liquid cooled shield technology repels molten metal during piercing allowing production piercing of 45 mm (1-3/4") on mild steel all the way up to 50 mm (2") on the XPR300 and up to 40 mm (1-9/16") on the XPR170 when using Hypertherm's exclusive argon-assist process.



Advanced arc stability

Superior arc steadiness from a modified shield gas impingement improves arc stability when coming out of a pierce hole or out of an acute angle delivering reduced lead-in lengths and improved cut quality.

Improved torch geometry

Superior bevel capability and performance thanks to an enhanced tapered torch design that features a 76° included angle and bevel rotation of up to 52°.

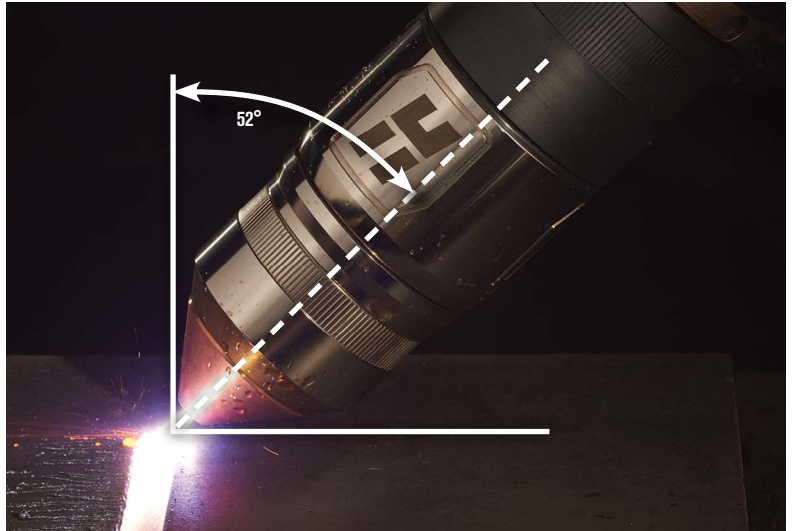

True Hole technology

XPR® True Hole® technology incorporates new arc segmentation protocols to automatically produce bolt hole quality on mild steel with diameter to thickness ratios of 1:1 up to 2:1.



Process control and delivery

State-of-the-art process control through a completely new concept in gas and fluid delivery. Four console options — Core™, CorePlus™, Vented Water Injection™ (VWI) and OptiMix™—offer unmatched mild steel cut quality with each console delivering successively enhanced cutting capabilities on stainless steel and aluminum. All consoles can be fully controlled through the CNC for high productivity and ease of use.

CorePlus, VWI, and Optimix gas connect consoles provide a source of argon gas which can be used for significantly improved marking and extended capacity piercing in some applications.



Gas-connect console gases/fluids				
	Core	CorePlus	Vented Water Injection (VWI)	OptiMix
O ₂ /N ₂ /Air	•	•	•	•
Ar		•	•	•
F ₅ /Ar/H ₂ O			•	•
H ₂ -N ₂ -Ar mixing				•

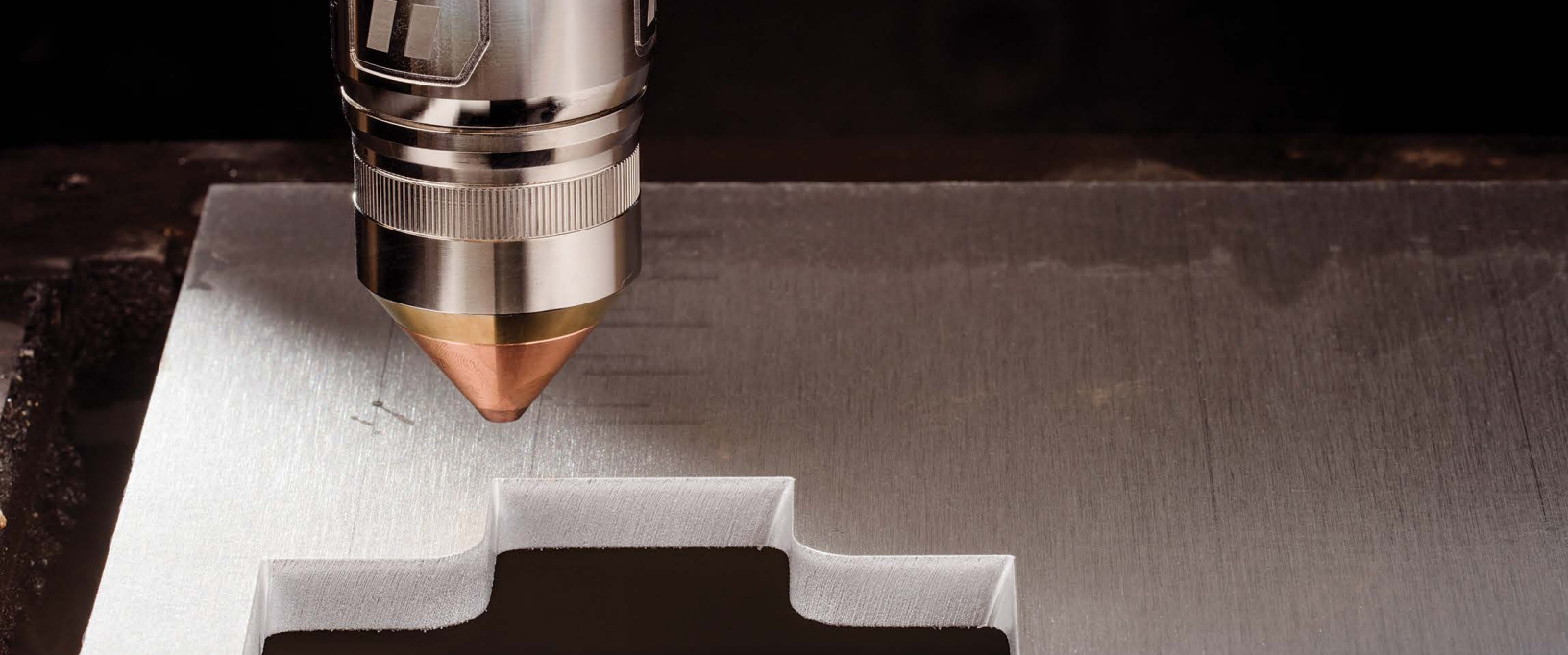

Core™ console

Unmatched mild steel cutting performance and superior angularity and edge finish on stainless steel up to 12 mm (1/2"). This is delivered through a new N₂ HDi® process that prevents the mixing of air into the plasma gas, creating an improved, brighter edge finish.



CorePlus™ console

All Core console capabilities plus argon marking and a more than 10% increase in piercing thickness with argon-assist enhanced piercing capability.



Vented Water Injection™ (VWI) console

All Core and CorePlus console capability plus significantly enhanced stainless steel and aluminum capabilities delivered with the addition of F5 HDi processes and patented Vented Water Injection (VWI).



OptiMix™ console

All the capabilities of the Core, CorePlus, and VWI consoles plus discrete 3-gas mixing—Ar, H₂, and N₂—for the world's most flexible, premium stainless steel and aluminum cutting capability.



Optimized productivity and reduced operating costs

Building on Hypertherm Associates' industry-leading productivity technologies, XPR® delivers faster cut speeds, higher quality cuts that reduce or eliminate secondary operations and increased consumable life with quicker set up time. These combine to further slash plasma system operating costs.

Technology benefits

- A valve in the torch receptacle delivers more rapid and precise control over gas flows for significantly longer oxygen process life and a greatly accelerated ramp down process. This elimination of ramp down errors in most applications enables a consumable life span nearly 3 times longer than other systems.
- New Cool nozzle™ flow technology contributes significant consumable life increases with greater ISO range 3 results than ever before.
- Increased power provides thicker pierce capability over previous systems in a production application. Argon-assist piercing delivers enhanced piercing capabilities for occasional jobs that require thicker piercing making the XPR a more versatile and productive tool in your factory.
- High quality argon marking using the same cutting consumables allows for a rapid and efficient changeover.

		XPR170		XPR300	
Maximum output power		35.7 kW		66.5 kW	
100% duty arc voltage		210 V		222 V	
Cut chart thickness		mm	inches	mm	inches
Pierce capacity	Mild steel (production)	35	1-3/8	45	1-3/4
	Mild steel (argon-assist)*	40	1-9/16	50	2
	Stainless steel	22	7/8	38	1-1/2
	Aluminum	25	1	38	1-1/2
Severance capacity	Mild steel	60	2-3/8	80	3-1/8
	Stainless steel	38	1-1/2	75	3
	Aluminum	38	1-1/2	50	2
Cut angle		ISO 9013 range		2-4	

*Argon-assist technology for thicker piercing is available with CorePlus, VWI and OptiMix gas consoles.

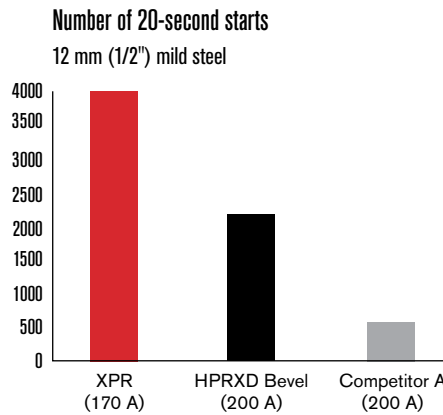
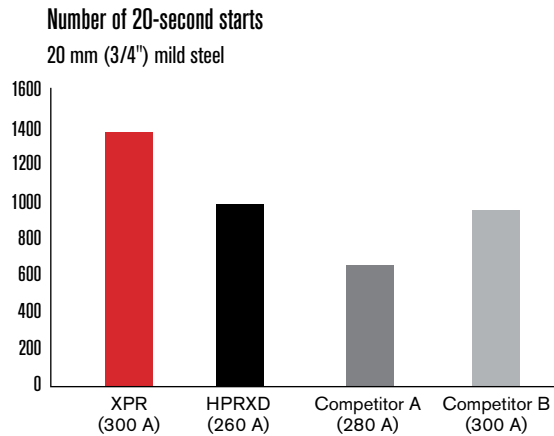

Argon marking





2021
184
S74-1



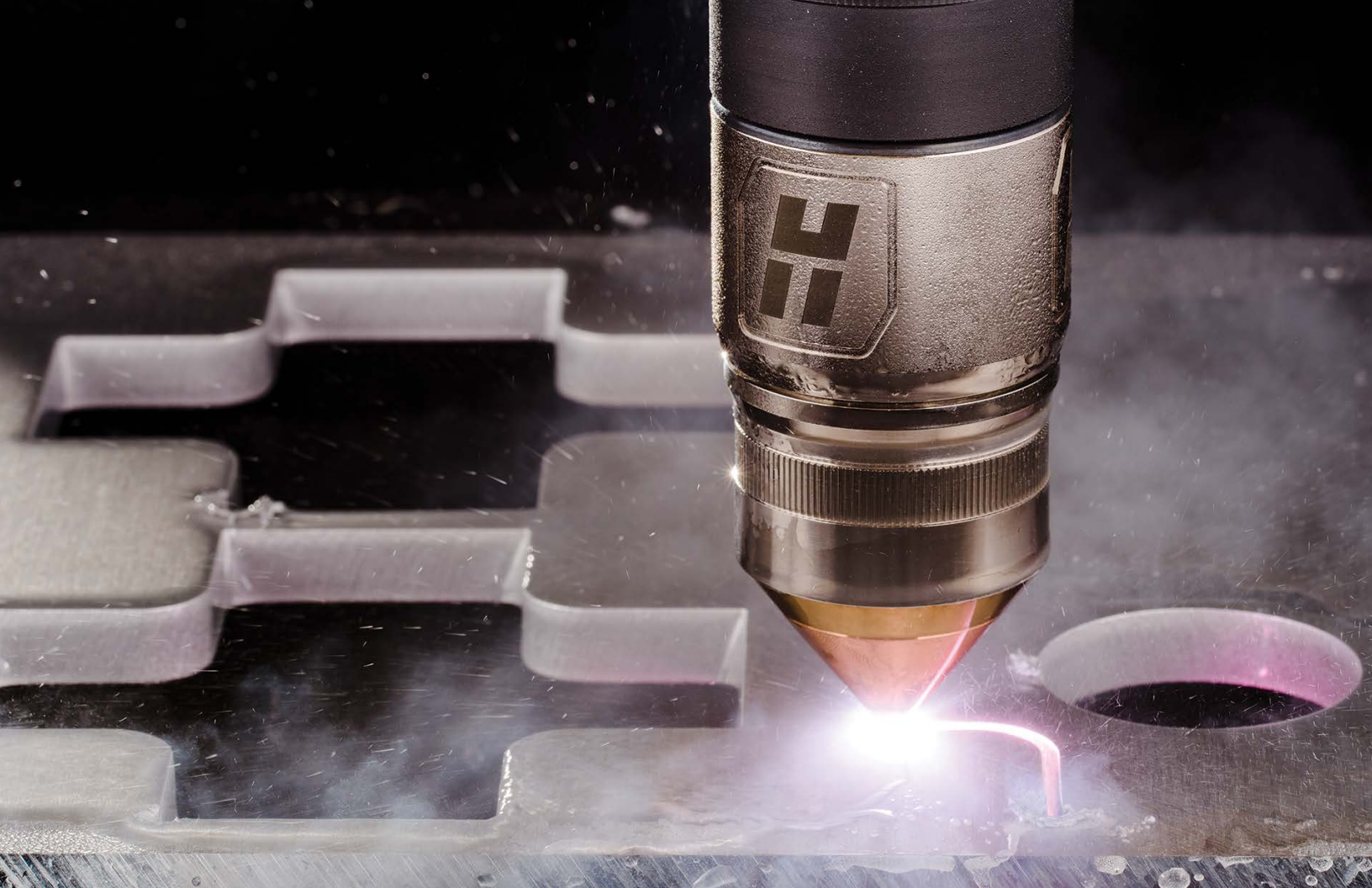

Engineered system optimization

XPR® is engineered to deliver the highest quality cuts and optimal system performance automatically. Advanced power supply technology delivers highly responsive, rapid system feedback, and automatically intervenes to eliminate events that negatively impact system efficiency and consumable life.

Improved operating and troubleshooting information

Sensors in the power supply deliver refined diagnostic codes and significantly enhanced system monitoring information. This reduces troubleshooting time and provides proactive system maintenance data for improved system optimization.

XPR's cutting-edge power supply features advanced chopper circuitry that instantaneously senses and responds to changes in arc voltage and current settings. This sophisticated Arc response technology™ delivers important benefits that reduce operating costs and increase productivity.

Arc response technology™

Automatic torch protection

The chopper module senses the onset of catastrophic electrode blowout failure and shuts down the system, protecting the torch from potential damage and enabling improved consumable utilization.

- Prevents torch failure
- Reduces operating cost

Automatic torch protection

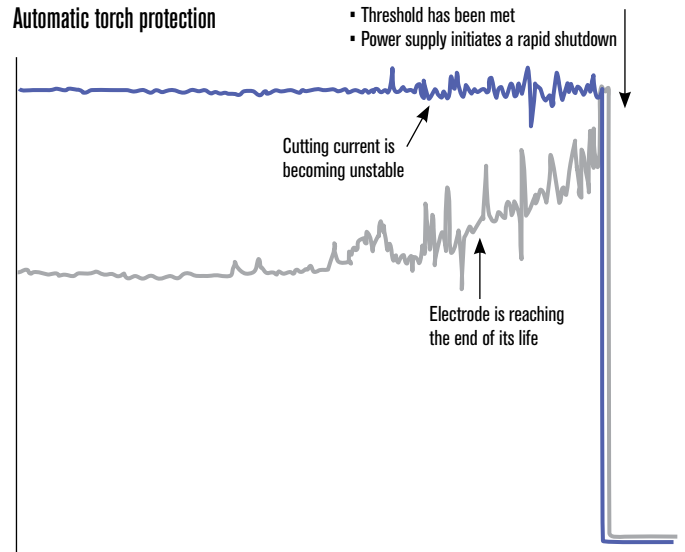

— Cutting current
— Arc voltage
— Plasma pressure

Automatic ramp-down error protection

The chopper module senses when a cut is about to end in an uncontrolled manner—without proper ramp down of current and gas flow. It automatically initiates a rapid ramp-down sequence protecting the electrode, dramatically extending consumable life—over 3 times that of systems that don't have this feature.

- Protects electrode
- Improves realized consumable life
- Reduces operating cost

Ramp-down error protection

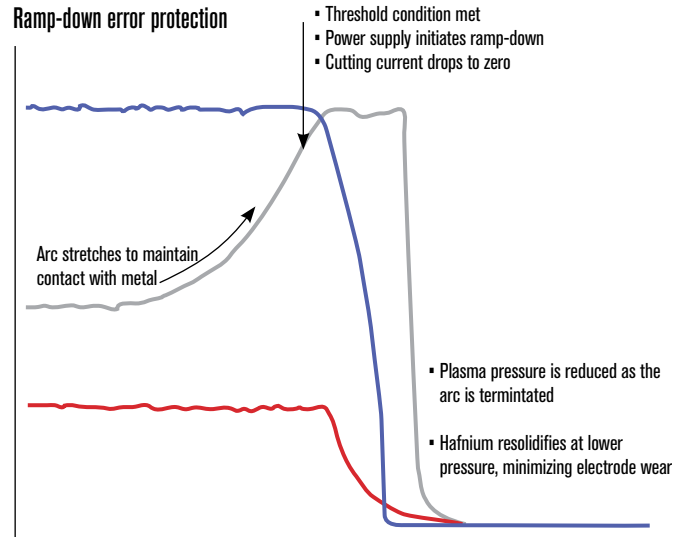



Ease of use

XPR® sets the new standard for achieving advanced system performance easily. From system set up and installation to connectivity and process optimization, XPR's intuitive operation and automatic system monitoring redefine easy plasma cutting.

- Fewer consoles and connections reduce components and complexity.
- Torch lead includes the EasyConnect™ tool-less connection to the TorchConnect™ console, reducing set up time and simplifying replacement.

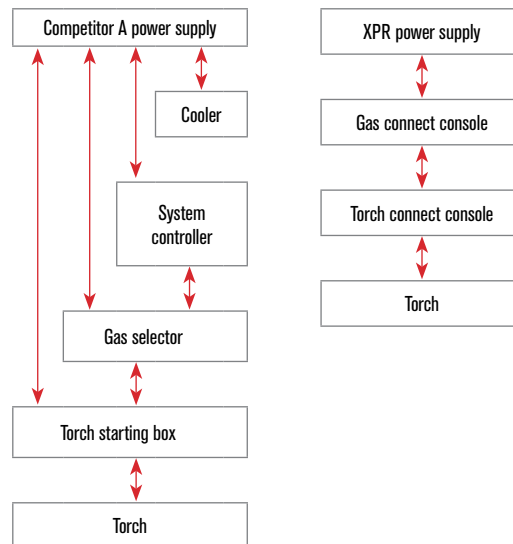

- All consoles feature advanced autogas capability enabling all cutting processes to be selected and driven directly from the CNC.
- Patented QuickLock™ electrode delivers easy ¼ turn tightening, reducing job setup time.
- Hypertherm's easiest and fastest torch disconnect design enables a rapid, one handed torch change.



- Built in WiFi connects operating and monitoring abilities to the mobile device dashboard.
- Easy to navigate and read.
- Allows the selection of cutting processes and the monitoring of multiple systems from most mobile devices and laptops.

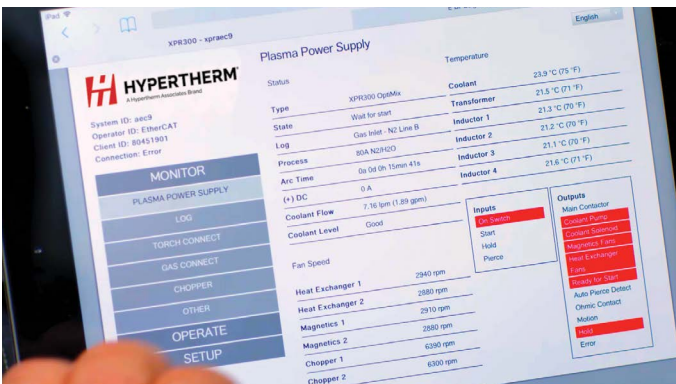
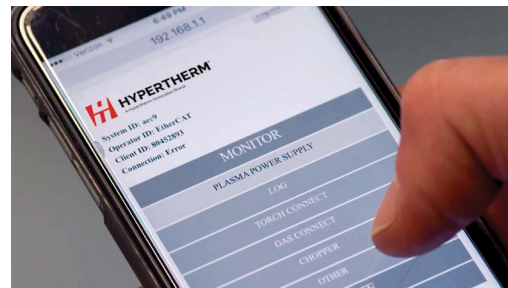

Environmental benefits

The engineering mission at Hypertherm Associates is to develop innovative technologies, products, and solutions that provide superior value to our customers, our owners, and our planet. We consider it critical to our success to reduce the environmental impact of everything we do. The XPR systems have been designed to be more efficient and less wasteful by reducing consumable use, energy and the carbon footprint.

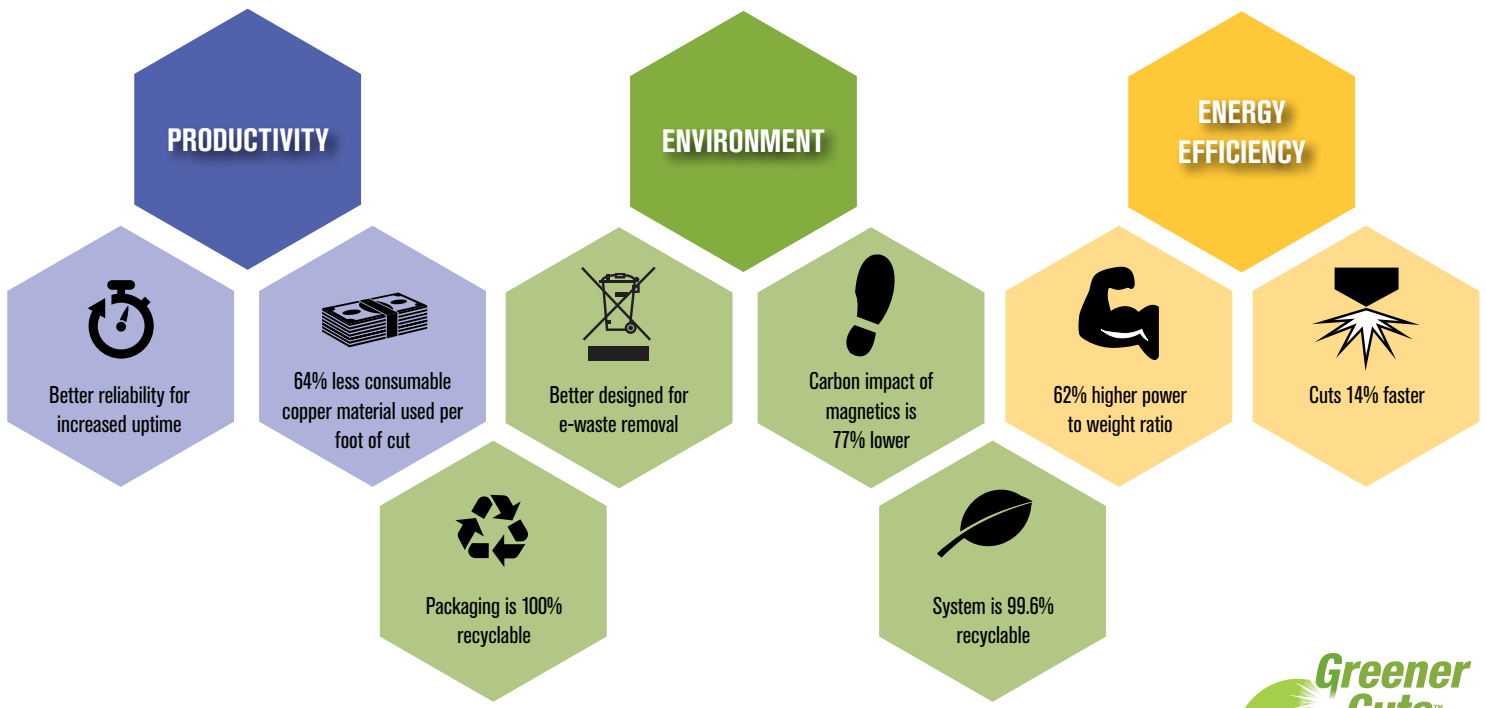

Reliability

XPR's engineering development is the culmination of tens of thousands of hours in testing, data analysis, and system tuning. Our development optimizes your uptime ensuring reliable machine performance even under highly stressful field conditions. The XPR® is Hypertherm Associates' smartest mechanized plasma system to date. On-board sensors continually monitor current, pressure, temperature, flow and compare to specifications during your operation to ensure optimum performance.

Specifications

General	XPR170	XPR300
Maximum open-circuit voltage	360 VDC	360 VDC
Maximum output current	170 A	300 A
Maximum output power	35.7 kW	66.5 kW
Output voltage	50-210 VDC	50-222 VDC
100% duty arc voltage	210 V	222 V
Duty cycle rating	100% at 35.7 kW, 40° C (104° F)	100% at 66.5 kW, 40° C (104° F)
Operational ambient temperature range	-10° C-40° C (14° F-104° F)	-10° C-40° C (14° F-104° F)
Power factor	0.98 @ 35.7 kW	0.98 @ 66.5 kW
Cooling	Forced air (Class F)	Forced air (Class F)
Insulation	Class H	Class H
EMC emissions classification (CE models only)	Class A	Class A
IP rating	IP21	IP21
Unit dimensions	H = 124.76 cm (49.12") L = 127.28 cm (50.11") W = 81.70 cm (32.17")	H = 124.76 cm (49.12") L = 127.28 cm (50.11") W = 81.70 cm (32.17")
Lift points	Top lift eye weight rating 680 kg (1,500 lb.) Bottom lift truck slots	Top lift eye weight rating 680 kg (1,500 lb.) Bottom lift truck slots

Console	Cutting gases	Current (A)	Thickness (mm)	Approximate cutting speed (mm/min)	Thickness (in.)	Approximate cutting speed (ipm)			
Mild steel									
Core, CorePlus, VWI, and OptiMix	O ₂ plasma O ₂ shield	30	0.5	5348	0.018	215			
			3	1153	0.135	40			
			5	726	3/16	30			
	O ₂ plasma Air shield	50	3	3820	0.105	155			
			5	2322	3/16	95			
			8	1369	5/16	55			
	O ₂ plasma Air shield	80	3	5582	0.105	225			
			6	3048	1/4	110			
			12	1405	1/2	55			
	O ₂ plasma Air shield	130	3	6502	0.135	240			
			10	2680	3/8	110			
			38	256	1-1/2	10			
O ₂ plasma Air shield	170	6	5080	1/4	200				
		12	3061	1/2	115				
		25	1175	1	45				
O ₂ plasma Air shield	300	60	152	2-3/8	6				
		12	3940	1/2	155				
		25	1950	1	75				
N ₂ shield	300	50	560	2	21				
		80	165	3	7				
Stainless steel									
Core, CorePlus, VWI, and OptiMix	N ₂ plasma N ₂ shield	40	0.8	6100	0.036	240			
			3	2683	0.105	120			
			6	918	1/4	32			
VWI and OptiMix	F ₅ plasma N ₂ shield	80	3	4248	0.135	140			
			6	1916	1/4	70			
			12	864	1/2	34			
OptiMix	H ₂ -Ar-N ₂ plasma N ₂ shield	170	10	1975	3/8	80			
			12	1735	1/2	65			
			38	256	1-1/2	10			
	H ₂ -Ar-N ₂ plasma N ₂ shield	300	12	2038	1/2	80			
			25	1040	1	40			
			50	387	2	15			
VWI and OptiMix	N ₂ plasma H ₂ O shield	300	75	162	3	6			
			12	2159	1/2	85			
			25	1302	1	50			
OptiMix	N ₂ plasma H ₂ O shield	300	50	403	2	15			
			Aluminum						
			Core, CorePlus, VWI, and OptiMix	Air plasma Air shield	40	1.5	4799	0.036	240
3	2596	1/8				85			
6	911	1/4				32			
VWI and OptiMix	N ₂ plasma H ₂ O shield	80	3	3820	1/8	140			
			6	2203	1/4	80			
			10	956	1/2	28			
	N ₂ plasma H ₂ O shield	130	6	2413	1/4	95			
			10	1702	3/8	70			
			20	870	3/4	35			
	N ₂ plasma H ₂ O shield	300	12	2286	1/2	90			
			25	1302	1	50			
			50	524	2	20			
OptiMix	H ₂ -Ar-N ₂ plasma N ₂ shield	300	12	3810	1/2	150			
			25	2056	1	80			
			50	391	2	15			

This does not represent a complete list of processes or thicknesses that are available



Constancy
of purpose

Drive to
innovate

Passion for
customer
success

The Hypertherm Associates corporate story

Hypertherm. OMAX. Centricut. ProNest. AccuStream, Robotmaster. These names and more represent the world's leading industrial cutting technologies and solutions, and they can all be found in one company: Hypertherm Associates. With constancy of purpose, a drive to innovate, and a passion for customer success, Hypertherm Associates is leading the industrial cutting and shaping industry.

Shaping Possibility

Since the founding of Hypertherm in 1968, we have always believed in the value of surpassing expectations. It's why we make continued investments in people. It's why we invest aggressively in ongoing product development. And now, it's why we'll be known as Hypertherm Associates: a 100% Associate-owned company composed of the world-class industrial cutting technologies and solutions you know and trust—plasma, waterjet, CAD-CAM, robotic software, and more—to help our customers succeed in ways that have never before been possible.

Hypertherm Associates builds on our legacy of challenging what's achievable with the products we create, the culture we foster, and the experience we deliver to our customers—and then goes further. Whether plasma, waterjet, or the consumables, software, and services that enable connected factories and optimized performance, the solutions that help our customers meet their business objectives can all be found in one place: Hypertherm Associates.

Committing to Success

Behind the name Hypertherm Associates lies a fundamental commitment to the success of people: our customers, partners, our Associates, and communities. Our dedication to 100% Associate ownership is a direct result of that commitment. By maintaining complete independence from external shareholders or other corporate entities, we can focus on our customers and partners to deliver exactly what they need. And because our Associates work together moving toward a common goal, they are an energized workforce dedicated to delivering a consistently superior customer experience.

Leading the Industry

From aerospace to agriculture and energy to infrastructure, the people, brands, and technologies of Hypertherm Associates can already be found everywhere advanced manufacturing is happening around the globe. In fact, hundreds of thousands of businesses are relying on Hypertherm Associates technologies and solutions right now for performance and reliability that help increase their productivity and profitability. And that's why companies worldwide turn to Hypertherm Associates to build ships, airplanes, and railcars, to construct steel buildings and bridges, to fabricate heavy equipment and wind turbines, and a whole lot more.

Through our portfolio of technologies and solutions, Hypertherm Associates employs more than 1,900 people and maintains operations and partner representation globally. With Hypertherm Associates, we've created a framework for growth and expansion that will allow us to bring the latest innovations to our customers more quickly, and with a deeper level of integration and customer support.

Hypertherm Associates is the evolution of a vision that continues to put our customers first, to solve their challenges, and to make it even easier to do business with us. Our global team is committed to continuously finding ways to make our company, our customers, and our communities more successful, and we're excited to have you with us as we continue our journey of shaping possibility.

SHAPING POSSIBILITY®

PLASMA | LASER | WATERJET | AUTOMATION | SOFTWARE | CONSUMABLES

For more information visit: www.hypertherm.com

HyPerformance, X-Definition, HyDefinition, XPR, HPR, Core, CorePlus, Vented Water Injection, PowerPierce, TorchConnect, True Hole, OptiMix, HDi, Cool nozzle, Arc response technology, EasyConnect, and QuickLock are trademarks of Hypertherm, Inc. and may be registered in the United States and/ or other countries

Please visit www.hypertherm.com/patents for more details about Hypertherm Associates patent numbers and types.

© 5/2023 Hypertherm, Inc. Revision 5
897060



**HYPERTHERM
ASSOCIATES™**

As 100% Associate owners, we are all focused on delivering a superior customer experience. www.hyperthermassociates.com/ownership

Environmental stewardship is one of Hypertherm Associates' core values. www.hyperthermassociates.com/environment

100% Associate-owned

